



Doosan Infracore Korea Office (HQ)  
 27/F, Doosan Tower 18-12, Euljiro-6Ga, Jung-Gu  
 Seoul 100-730 Korea  
 Tel : 82 2 3398 8114

[www.doosaninfracore.com/ce/](http://www.doosaninfracore.com/ce/)



# DX55W

Engine Power : SAE J1349, net 40.8 kW(54.7HP)@2,400rpm  
 Operational Weight : 5,550 kg (12,236 lb)  
 Bucket capacity(SAE) : 0.175 m<sup>3</sup> (0.23 cu.yd)





“When there’s more to do,  
Doosan gets more done”



**DX**  
**55w**



The new DX55W hydraulic excavator has all the advantages of the previous model, and now offers additional added value to the operator.

The new DX55W was developed with the concept of “providing optimum value to the end user.” In concrete terms, this translates, into :

**Increased production and improved fuel economy** is attributed to the electronic optimization of the hydraulic system and the new generation engine.

**Improved ergonomics** increases comfort and excellent all around visibility ensuring a safe and pleasant working environment.

**Improved reliability** is achieved through the use of high performance materials combined with new methods of structural stress analysis, which leads to increased component life expectancy, thus reducing operating costs.

**Reduced maintenance** increases the availability and reduces operating costs of the excavator.



# Comfort

DX55W

This standard-duty machine, offers a spacious operating area that is only found in medium and heavy-duty machines. The working controls in the cabin are ergonomically designed to ensure convenience and comfort for the operator. Resulting in operator comfort and convenient operation.



## Good visibility (visual field in 360°)

The operator's cabin is remarkably increased and good visibility is ensured thanks to the access improved by applying chassis to left and has excellent all round visibility.

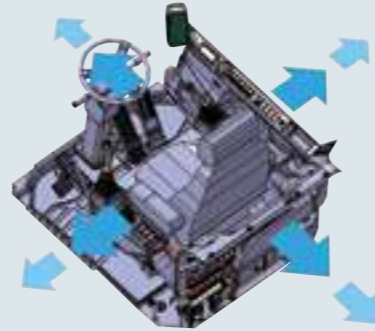

Rear Camera



Front window



Rear window



Sub window



Left / Right Side mirror

## Comfortable Operating Area

The internal operating controls are arranged in a convenient and ergonomic fashion. This allows for maximized operating efficiency. A large capacity air-conditioning system has been installed for operator comfort in all seasons. The open and spacious cabin provides the operator with a wide field of view for the best possible working conditions.



Thermometer for cooling water

Fuel gauge

Fixed-type LED Instrument Panel

## Fixed-Type Instrument Panel

The centralized display panel provides comprehensive information about the status of the machine in an easy to read format. The high quality display panel is waterproof and all information can be seen at a glance.



Air-Conditioner Filter

## High-Output Air-Conditioner and Defroster

The air-conditioner capacity has been greatly improved and the vents have been installed at both the front and rear of the operator's seat to maximize air-conditioning efficiency. A defroster has been installed to prevent the front windshield from becoming frosted in the cold season resulting in safer operation.



475mm (1'7")



324mm (1')

## Enlarged entrance and exit

As entrance and exit are enlarged, accessibility is improved for getting on and off the vehicle. Since the front workspace is maximized, the inconvenience in operating equipment is minimized.



## Control Stand

The left and right control stands are ergonomically placed for convenient operation. The control stand surfaces have ample room to install several option switches. The uni-body plastic design provides the operator with a spacious and comfortable cabin environment.



Comfortable 2-stage sliding seat



Comfortable tilting seat

## Suspension Seat

Since the seat cushion position and cushion angle can be adjusted in addition to the 2-step slide control function, the seat can be controlled in accordance with personal preference convenience is further improved via the seat back pocket, lumbar support and seat heater. (Option)



## Switch

The ergonomically placed switches maximizes convenience for the operator.



## A/C Control Panel

As semi-automatic air conditioner is applied in 5 switching modes, it can be controlled in the position and performance desired by operator.



## Dozer Control

The Dozer Control Lever is positional above the left-hand control stand to secure easy and convenient access.



## Handle tilting

As the upper part of steering column can be easily tilted by simple operation of front lever, the operator can enter and come out of the cabin more easily.



## Transmission lever

As hydraulic transmission method is adopted, transmission is possible even after stop. Thanks to transmission system which is more convenient for operation, it is far easier to move in the site.



## Joystick

The hydraulic joystick levers have very comfortable grips that allow the operator to perform precise operations very easily. As there are 3 switches on the upper side, each attachment can be operated easily.



## Floor Plate (Rubber mat)

The breaker pedal(left) is installed in a very spacious and convenient location. In addition, the rubber floor mats contribute to a very comfortable environment.



Wide Storage space



Seat back pocket



Rubber mounting



# Performance

DX55W

DX55W ensures best performance with powerful excavating force and high-tech hydraulic system for better operation efficiency at any work site! Excellent performance is its basic feature! Its excellent performance with safety and convenience taken into account will help safe and convenient operation.



### Boom swing

The convenient boom swing function provides the ability to work in very narrow areas. The newly designed swing bracket and the boom swing cylinder size ensures powerful and stable boom swing performance.

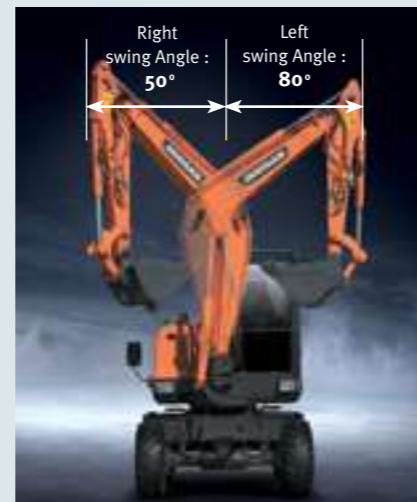
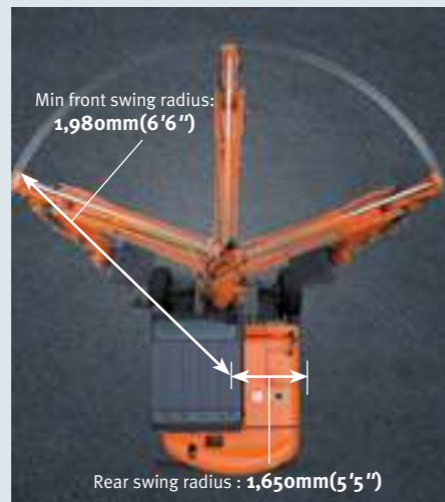

### YANMAR 4TNV98

The 54.7HP(SAE J1349, net) engine produces outstanding power and is known for its durability. This results in excellent operation in high-load operations. In addition, it features a low noise and low emissions suitable for operation in noise sensitive areas and at night.



### Blow out

As the temperature of air flowing into cabin is lowered by discharging the air flowing from outside to radiator, agreeable work environment is ensured in the cabin.



### Large dozer blade

As the ascending and descending speed of dozer blade is increased, work efficiency is maximized. Since the mudguard of blade is extended to both ends, mud does not go behind dozer while working.



### Higher gradability and work capability

Thanks to the strong driving force based on high performance engine power and the highest swing limit angle in the same class, the product shows distinguished capability in working on the slope.



### Swing device

As swing torque is increased by some 10% compared to the old model, efficient work is ensured. Since the lubricant oil of swing reducer is used as hydraulic oil, no additional lubrication or refueling is required.



### Main control valve

The machine can be precisely controlled in the single and complex operation. For complex operation, the circuit that ensures the optimal front operation is adopted. Thanks to boom holding function, it prevents the boom from self-lowering.



### The front speed accelerated by 20% ↑

As the working speed of boom and arm is accelerated by 20% compared to the old model, more work can be done in the same hours. At the leveling, detailed operation is possible as joystick in the cabin is improved to long lever.\*



\* The measured value is based on our test and the compared equipment is Doosan V model.



# Reliability

DX55W

The reliability of an item of plant contributes to its overall lifetime operating costs. DOOSAN uses computer-assisted design techniques, highly durable materials and structures then test these under extreme conditions. Durability of materials and longevity of structures are our first priorities.

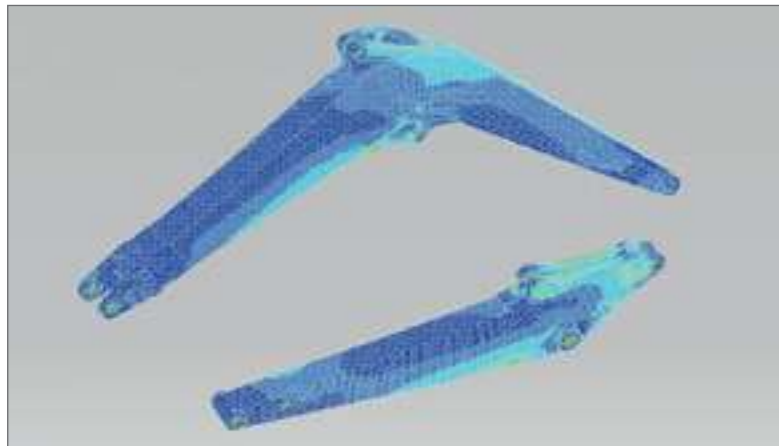

**Strengthened Boom**  
The shape of the boom has been optimized by finite elements design, allowing uniform load distribution throughout the structure. This combined with increased material thickness means improved durability and reliability by limiting element fatigue.

**Arm Assembly**  
In the arm assembly greater strength has been gained by using cast elements and reinforcement around the bosses to give increased life.

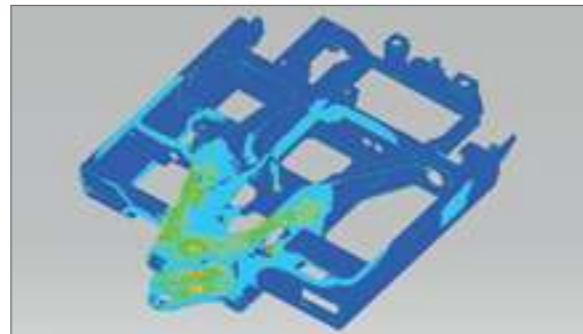

**D-type Frame**  
The D-type frame design adds strength and minimizes distortion due to shocks.

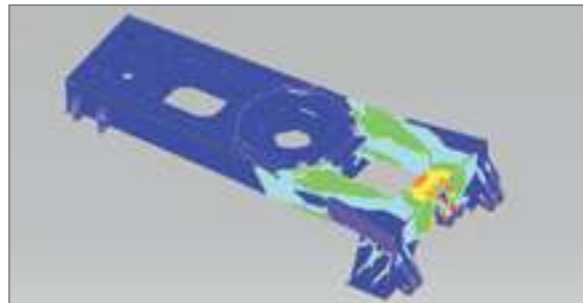

**Stress Analysis Design (FEM) and Innovative Manufacturing Technique Provides a Strong and stable Undercarriage**  
As Chassis Frame and Dozer Blade are designed by interpretative and techniques and reliability testing using 3 dimension CAD tools, durability and reliability are improved.



**Bushing**  
A highly lubricated metal(sintered bushing) is used for the boom, arm and bucket pivot in order to increase the lifetime and extend the greasing intervals to 250 hours.



**Polymer shim**  
As polymer shim is adopted, the connection and wear on the lateral surface of pin joint is prevented when operating front.



**Protective plate**  
As steel cover is installed on the front surface of front axle and rear axle, the damage of central aluminum cover is solved fundamentally.



**Front oil leakage preventing valve**  
As the operating method of the valve is improved, oil does not leak even under high pressure, thereby ensuring the stable work performance.



**Head lamp**  
As vision is improved for work in day and night, the work convenience is increased.



**Combination key**  
As a multi key is applied to the chrome-coated knob and fuel cap, security is enhanced.



**Undercarriage Design**  
A rigid, welded frame provides excellent durability. Efficient hydraulic lines routing, transmission protection and heavy duty axles make the undercarriage perfect for wheel excavator applications. Both outriggers and dozer blade are pin type for maximum flexibility. An optional work tool restraint bar is available.



**Excellent work stability and oscillating**  
As the center of gravity is moved to rear part, the oscillation of equipment is prevented. The axle realizes more stable work on rough surface and uneven site thanks to wide angle of upper and lower adjustment.



**Increased diameter of ram cylinder**  
As the diameter of ram cylinder is increased by 36% compared to the old model and supporting distance is elongated, the equipment stability is much improved. Thanks to the adoption of auto ram lock system, the equipment is much more convenient.

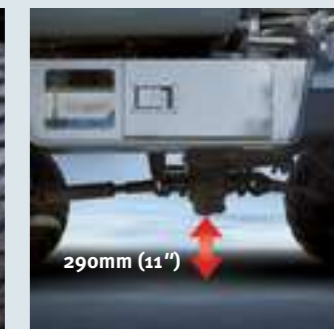

**Height from ground to axle**  
As mission is attached on higher part, traveling on rough surface and marsh is improved.



**Loading capacity sensor (optional)**  
As the sensor makes warning sound in the hoisting work that exceeds the hoisting capacity by detecting the weight of hoisted cargo, the work can be done more safely.



**Chassis frame in bending type**  
Since the structure is changed to bending type applied to medium and large equipment, durability is improved remarkably.



**Reducing the height of attaching swing bearing**  
As the height of attaching swing bearing is reduced by 65% compared to the old model, stability is improved remarkably.

\* The measured value is based on our test and the compared equipment is Doosan V model.



# Maintenance

## DX55W

The most advanced technology developed by Doosan was integrated into the DX55W excavator providing powerful performance and simple, easy maintenance. This provides the operator with convenient maintenance check points and maximizes the work efficiency of the DX55W.



### Easy maintenance

Access to the various radiators and coolers is very easy, making cleaning easier. Access to the various parts of the engine is from the top through side.



### Countweight & hood

As a cast counterweight is applied, deformation by impact is minimized. Thanks to the bonnet made of metton, the engine is further protected from external obstacle.



### Radiator

The large-capacity radiator provides excellent performance in severe and continuous operations. The assemblable dust net on oil-cooler front side prevents overheating from filth.



### Condenser

As separate type condenser is attached, the refrigerating performance of condenser is excellent and cleaning is easier.



### Oil filter/Fuel filter

The engine oil filter is attached to the engine body and extends out for easy maintenance.



### Air Breather

The mounted large-capacity air breather protects the pump from possible damage that may be caused by cavitations. Since only internal element instead of the entirety can be replaced when exchanging, it is more practical.



### Tool box and Storage Places

A large sized and lockable tool box is mounted on the left side of undercarriage and the storage places for grease can be provided in the right side of undercarriage.



### Oil Gauge

Hydraulic oil level can be easily checked through the gauge on the side of the hydraulic tank.



### Grease Piping

Integrated grease piping is designed for easy maintenance of the swing bearing and swing cylinder.



### Air cleaner

The large capacity forced air cleaner removes over 99% of airborne particles, reducing the risk of engine contamination, making the cleaning and cartridge change intervals greater.



### Muffer

As a small muffer is applied, noise and heat is minimized.



### Battery

Opening the battery cover, the operator can easily check the parts.



### Water separator

Since water separator is used to prevent the malfunction of fuel system caused by water in fuel, the operator can easily check it on the gauge.



### Compressor Check up interval 250Hrs

Sufficient space is provided for easy fan belt tension adjustment or replacement. As check-up intervals are considerably increased to 250Hrs by attaching a B-type belt, servicing is made far more convenient.



### Engine mounting rubber

As a sandwich-typed engine mounting rubber with excellent durability and dustproof property is adopted, the engines vibration is not transmitted to the machine.



# DX55W

## Technical specifications

### ENGINE

<b>Model</b>	YANMAR 4TNV98-E
<b>Number of cylinders</b>	4
<b>Nominal flywheel power</b>	40.8 kW(54.7HP) @ 2,400 rpm (SAE J1349, net)
<b>Max torque</b>	21.0 kgf.m(206 Nm) at 1,550 rpm
<b>Piston displacement</b>	3,319 cc (202.5 cu.in)
<b>Bore &amp; stroke</b>	Φ98 mm x 110 mm (3.9" X 4.3")
<b>Starter</b>	12 V / 3 kW
<b>Batteries</b>	1 x 12 V / 100 Ah
<b>Alternator</b>	12 V / 60 Ah

### HYDRAULIC SYSTEM

2 Variable displacement axial piston tandem type pumps.  
2 Gear pumps and control valve (11-spool) of section block construction.  
This original design enables both independent and combined operations of all function, joystick control type levers.

<b>Main pumps</b>	2 variable displacement axial piston pumps max flow: 2 x 60 l / min (2 X 15.9 US gpm, 2 X 13.2 Imp gpm)
<b>Pilot pump</b>	Gear pump - max flow: 20 l / min (5.3 US gpm, 4.4 Imp gpm)
<b>Maximum system pressure</b>	Boom/Arm/Bucket: 230 kgf/cm <sup>2</sup> (225 bar) Travel: 230 kgf/cm <sup>2</sup> (225 bar) Swing: 210 kgf/cm <sup>2</sup> (205 bar)

### SUPER-STRUCTURE REVOLVING FRAME

A deep, full-reinforced box section. Heavy gauge steel plates used for ruggedness.

### HYDRAULIC CYLINDERS

High-strength piston rods and tubes are used.  
A cylinder cushion mechanism is provided for the boom and arm cylinders to assure shock-free operation and extend the life of the cylinders.

Cylinders	Quantity	Bore x Rod diameter x stroke
Boom	1	110 X 60 X 712mm(4.3" X 2.3" X 2'4")
Arm	1	85 X 55 X 873mm(3.3" X 2.2" X 2'10")
Bucket	1	80 X 50 X 600mm(3.1" X 1.9" X 2')
Dozer	1	110 X 60 X 160mm(4.3" X 2.4" X 6.3")
Booming swing	1	95 X 50 X 558mm(3.7" X 2.0" X 1'10")

### OPERATOR'S CAB

A roomy, independent, shock and noise-free operator's cab, four-side safety glass windows gives all-round visibility.  
Front window slides up and stores in the roof and side window can be opened for ventilation. Fully adjustable suspension seat. Air conditioner. ISO standard cab.

Noise Levels (dynamic value)		
<b>LwA External noise</b>		
Guaranteed Sound Power Level	97.4dB (A) (2000/14/EC)	
<b>LpA Operator noise</b>	76dB (A) (ISO 6396)	

### CONTROL. 2 IMPLEMENT LEVERS

Travel lever pedal pilot pressure control type. Right lever is boom and bucket control, left lever for swing and arm control.

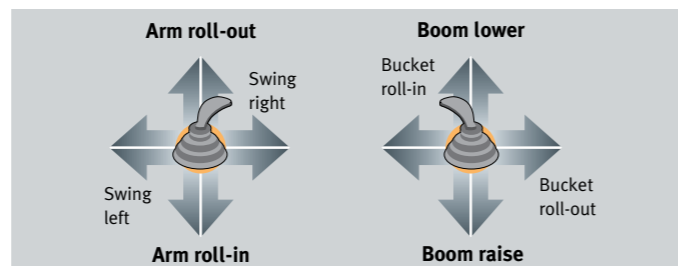

### SWING MECHANISM

High-torque, axial piston motor with planetary reduction gear bathed in oil. Swing bearing is single-row, shear type ball bearing with induction-hardened internal gear. Internal gear and pinion gear immersed in lubricant. A two position swing lock secures the upper structure for transportation.

<b>Swing speed</b>	8.7 rpm
<b>Rear swing radius</b>	1,650 mm(5'5")

### DRIVE

Fully hydrostatic driven, 2 speed mechanical shift transmission, variable displacement, high torque, axial piston motor, foot pedal controls provide smooth travel, hub reduction type front steering axle and rear rigid axle.

<b>Travel speed(High/Low)</b>	30/10 km/h (19 /6 mph)
<b>Maximum traction force</b>	3,300 kgf (7,275 lbf)
<b>Maximum grade</b>	35° / 70%

### UNDERCARRIAGE

Heavy-duty frame, all-welded stress-relieved structure. Top grade materials used for toughness. Specially heat-treated connecting pins.  
12-16.5-12PR(OTR) tubeless single tires, front axle oscillating hydraulically (+/-5).

### BUCKET

Capacity		Width		Weight	Recommendation
PCSA, heaped	CECE heaped	Without side cutters	With side cutters		3,000mm (9'10") Boom
0.175m <sup>3</sup> (0.229yd <sup>3</sup> )	0.15m <sup>3</sup> (0.196yd <sup>3</sup> )	654mm (2'2")	724mm (2'5")	141 kg (311 lb)	B
0.19m <sup>3</sup> (0.249yd <sup>3</sup> )	0.17m <sup>3</sup> (0.222yd <sup>3</sup> )	712mm (2'4")	784mm (2'6")	150 kg (331 lb)	B
0.07m <sup>3</sup> (0.092yd <sup>3</sup> )	0.06m <sup>3</sup> (0.078yd <sup>3</sup> )	300mm (1')	362mm (1'2")	96 kg (212 lb)	A

A. Suitable for materials with density of 2,000 kg/m<sup>3</sup> (3,370 lb/CU • yd) or less  
B. Suitable for materials with density of 1,600 kg/m<sup>3</sup> (2,700 lb/CU • yd) or less  
C. Suitable for materials with density of 1,100 kg/m<sup>3</sup> (1,850 lb/CU • yd) or less

### BRAKE

Full sealed wet discs service brakes operated fully hydraulic and rear axle sealed wet discs parking brake operated hydraulically.

### WEIGHT

Operating weight, including single tire and 1,920mm dozer blade, or twin tire and 2,290mm dozer blade, operator, lubricant, coolant, full fuel tank and the standard equipment. Weight are 141 k (311 lb) bucket.

Arm (mm)	Dozer (Width X Height mm)	Tire	Machine	Front Axle	Rear Axle
1,600	1,920 x 500	Single	5,550 kg (12,235 lb)	2,650 kg (5,842 lb)	2,900 kg (6,393 lb)
	2,290 x 500	Twin	5,910 kg (13,029 lb)	2,830 kg (6,238 lb)	3,080 kg (6,790 lb)
1,900	1,920 x 500	Single	5,570 kg (12,280 lb)	2,690 kg (5,930 lb)	2,880 kg (6,350 lb)
	2,290 x 500	Twin	5,930 kg (13,073 lb)	2,870 kg (6,327 lb)	3,060 kg (6,746 lb)

### REFILL CAPACITIES

<b>Fuel tank</b>	120 l (31.7 US gal, 26.4 Imp gal)
<b>Cooling system (Radiator capacity)</b>	10 l (2.6 US gal, 2.2 Imp gal)
<b>Engine oil</b>	11.6 l (3.1 US gal, 2.6 Imp gal)
<b>Final drive (each)</b>	1.5 l (0.4 US gal, 0.3 Imp gal)
<b>Hydraulic system</b>	147.8 l (39 US gal, 32 Imp gal)
<b>Hydraulic tank</b>	72 l (19 US gal, 16 Imp gal)

# DX55W

## Dimensions

### DIMENSIONS

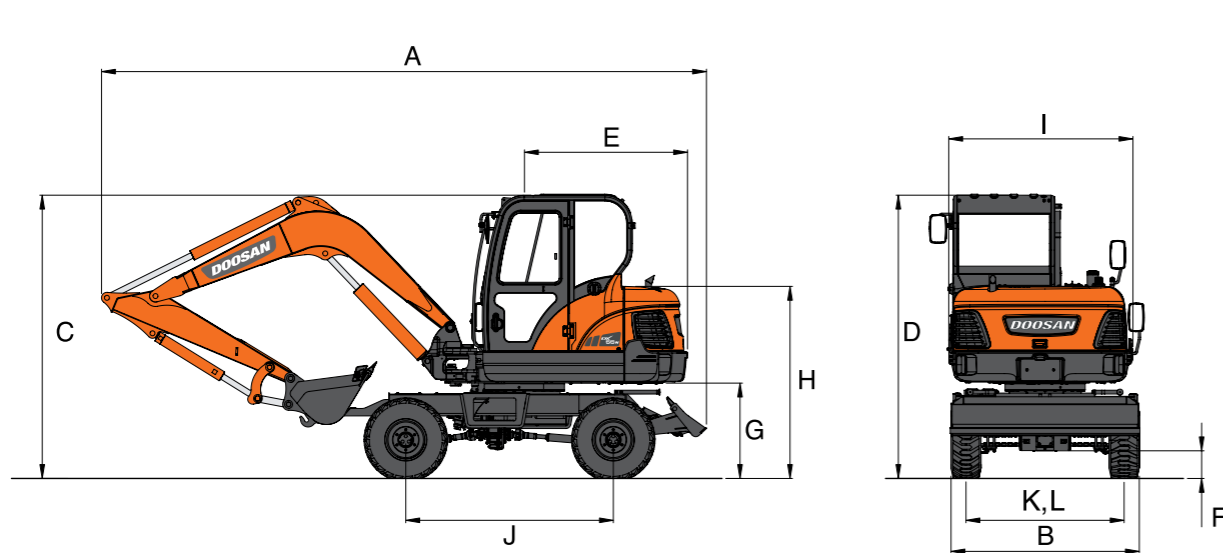

Boom type	3,000mm(9'10")	
Arm type	1,600mm(5'3")	
Tire type	Single tire	Twin tire
A Overall length	6,120mm(20'1")	←
B Overall width	1,920mm(6'4")	2,290mm(7'6")
C Overall height	2,855mm(9'4")	←
D Overall height (to top of cab)	2,855mm(9'4")	←
E Tail swing radius	1,650mm(5'5")	←
F Minimum ground clearance	290mm(1)	←
G Upper structure ground clearance	980mm(3'3")	←
H Engine cover height	1,935mm(6'4")	←
I Upper structure width	1,850mm(6'1")	←
J Wheel base	2,100mm(6'11")	←
K Tread width	1,600mm(5'3")	2,275mm(7'6")

### DIGGING FORCE (ISO)

Bucket (PCSA)	0.175m <sup>3</sup>	
Digging force	4,060 kgf	
	39.8 kN	
	8,954 lbf	
Arm	1,600mm	1,900mm
Digging force	2,690 kgf	2,410 kgf
	26.4 kN	23.6 kN
	5,939 lbf	5,313 lbf

# DX55W

## Working range

### WORKING RANGE

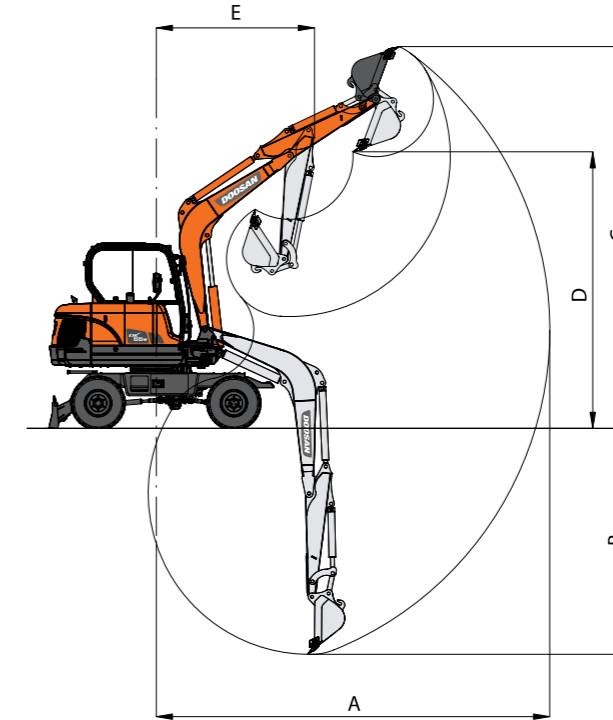

Boom type	3,000mm(9'10")	
Bucket type (SAE)	0.175m <sup>3</sup> (0.23yd <sup>3</sup> )	
Arm type	1,600mm(5'3")	1,900mm(6'3")
A Max. Digging Reach	6,110mm(20'1")	6,400mm(21')
B Max. Digging Depth	3,495mm(11'6")	3,795mm(12'5")
C Max. Digging Height	5,980mm(19'7")	6,170mm(20'3")
D Max. Dump Height	4,265mm(14')	4,455mm(14'7")
E Min. Swing Radius	1,980mm(6'6")	1,990mm(6'6")

### Undercarriage with front cradle and rear dozer

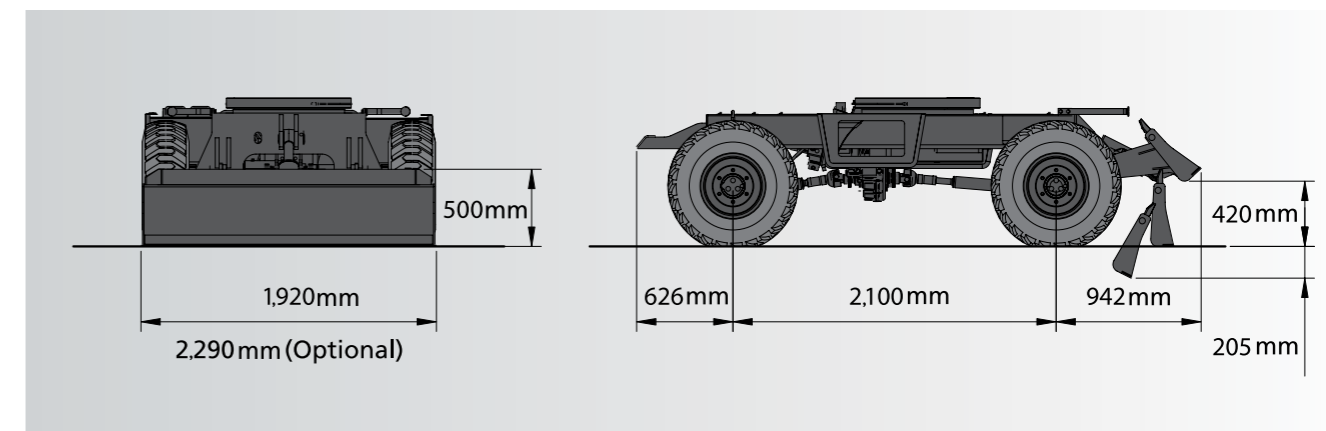



# DX55W

## Lifting Capacity

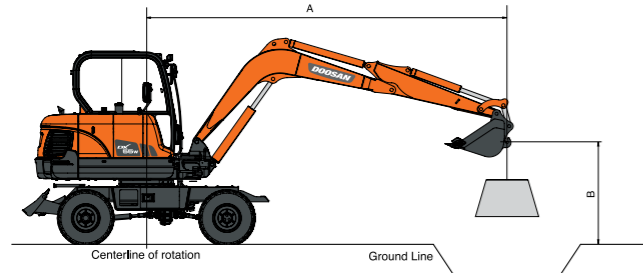

- A : Load radius from centerline of rotation
- B : Load point height
- : Rated lift capacity-over side (Free on Wheel/Dozer Up)
- : Rated lift capacity-over front (Free on Wheel/Dozer Up)

### Dozer up, Front with 1,600mm(5'3") Arm

Metric Unit : 1,000kg

A(m)	2		3		4		5		Max. Reach		A(m)
4					*0.98	*0.98			*0.87	0.82	4.54
3					*1.14	0.99	*0.96	0.68	*0.89	0.68	5.03
2	*2.33	*2.33	*1.90	1.47	*1.44	0.95	1.19	0.67	*0.96	0.62	5.25
1	*1.19	*1.19	*2.61	1.38	1.65	0.91	1.17	0.65	1.08	0.60	5.25
O (Ground)	*2.14	*2.14	2.59	1.34	1.62	0.88	1.15	0.64	1.15	0.64	5.01
-1	*3.38	2.60	2.58	1.34	1.61	0.88			1.34	0.74	4.51
-2	*4.20	2.65	*2.52	1.36					1.93	1.05	3.60

Feet Unit : 1,000lb

A(ft)	10		15		Max. Reach		A(ft)
15					*1.96	*1.96	13.44
10			*2.50	1.76	*1.96	1.50	16.44
5	*4.90	3.07	2.98	1.67	2.24	1.33	17.31
O (Ground)	5.55	2.90	2.91	1.60	2.53	1.40	16.45
-5	5.56	2.90			3.44	1.88	13.45

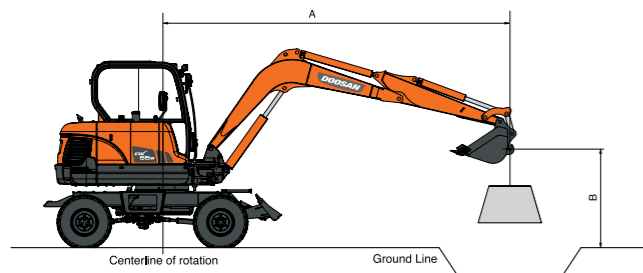

- A : Load radius from centerline of rotation
- B : Load point height
- : Rated lift capacity-over side (Free on Wheel/Dozer Up)
- : Rated lift capacity-over front (Free on Wheel/Dozer Up)

### Dozer up, Rear with 1,600mm(5'3") Arm

Metric Unit : 1,000kg

A(m)	2		3		4		5		Max. Reach		A(m)
4					*0.98	*0.98			*0.87	0.82	4.54
3					*1.14	0.99	0.79	0.68	0.78	0.68	5.03
2	*2.33	*2.33	1.71	1.47	1.10	0.95	0.77	0.67	0.71	0.62	5.25
1	*1.19	*1.19	1.62	1.38	1.06	0.91	0.65	0.65	0.70	0.60	5.25
O (Ground)	*2.14	*2.14	1.58	1.34	1.03	0.88	0.64	0.64	0.74	0.64	5.01
-1	3.17	2.60	1.58	1.34	1.02	0.88			0.86	0.74	4.51
-2	3.22	2.65	1.60	1.36					1.22	1.05	3.60

Feet Unit : 1,000lb

A(ft)	10		15		Max. Reach		A(ft)
15					*1.96	*1.96	13.44
10			2.02	1.75	1.73	1.50	16.44
5	3.58	3.07	1.94	1.67	1.55	1.33	17.31
O (Ground)	3.40	2.90	1.87	1.60	1.63	1.40	16.45
-5	3.41	2.90			2.19	1.88	13.45

1. The weight of bucket is 142kg  
2. Load point is the hook on the back of the bucket

3. \*Rated loads are based on hydraulic capacity  
4. Rated loads do not exceed 87% of HYD. Capacity or 75% of tipping capacity.

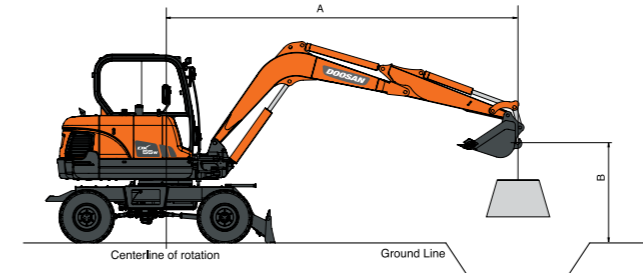

- A : Load radius from centerline of rotation
- B : Load point height
- : Rated lift capacity-over side (Free on Wheel/Dozer Up)
- : Rated lift capacity-over front (Free on Wheel/Dozer Up)

### Dozer down, Rear with 1,600mm(5'3") Arm

Metric Unit : 1,000kg

A(m)	2		3		4		5		Max. Reach		A(m)
4					*0.98	*0.98			*0.87	*0.87	4.54
3					*1.14	*1.14	*0.96	0.87	*0.89	0.87	5.03
2	*2.33	*2.33	*1.90	*1.90	*1.44	1.22	*1.27	0.86	*0.96	0.79	5.25
1	*1.19	*1.19	*2.61	1.82	*1.76	1.17	*1.42	0.84	*1.10	0.78	5.25
O (Ground)	*2.14	*2.14	*2.95	1.77	*1.97	1.15	*1.42	0.83	*1.35	0.82	5.01
-1	*3.38	*3.38	*2.93	1.77	*1.99	1.14			*1.67	0.96	4.51
-2	*4.20	3.69	*2.52	1.80					*1.94	1.36	3.60

Feet Unit : 1,000lb

A(ft)	10		15		Max. Reach		A(ft)
15					*1.96	*1.96	13.44
10			*2.50	2.24	*1.96	1.92	16.44
5	*4.90	4.00	*3.14	2.15	*2.24	1.72	17.31
O (Ground)	*6.34	3.82	*3.69	2.08	*2.99	1.82	16.45
-5	*6.01	3.82			*3.96	2.45	13.45

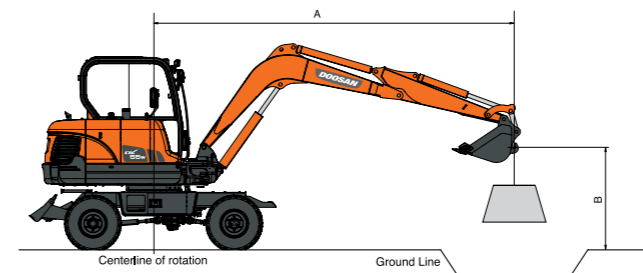

- A : Load radius from centerline of rotation
- B : Load point height
- : Rated lift capacity-over side (Free on Wheel/Dozer Up)
- : Rated lift capacity-over front (Free on Wheel/Dozer Up)

### Dozer up, Front with 1,900mm(6'3") Arm

Metric Unit : 1,000kg

A(m)	2		3		4		5		Max. Reach		A(m)
5									*0.79	*0.79	4.10
4									*0.75	0.72	4.89
3					*0.98	*0.98	*1.04	0.68	*0.76	0.61	5.35
2	*2.92	2.87	*1.63	1.49	*1.30	0.95	*1.17	0.67	*0.80	0.56	5.55
1	*1.46	*1.46	*2.41	1.39	1.65	0.91	1.16	0.64	*0.90	0.54	5.55
O (Ground)	*1.99	*1.99	2.58	1.34	1.61	0.88	1.14	0.63	1.04	0.57	5.33
-1	*2.97	2.57	2.57	1.32	1.60	0.86			1.19	0.65	4.87
-2	*4.43	2.61	2.58	1.34	1.61	0.88			1.58	0.86	4.05
-3	*2.92	2.70							*2.24	1.92	2.45

Feet Unit : 1,000lb

A(ft)	10		15		Max. Reach		A(ft)
15					*1.68	*1.68	14.74
10					*1.66	1.35	17.49
5	*4.38	3.09	*2.92	1.67	*1.86	1.20	18.30
O (Ground)	5.54	2.88	2.89	1.58	2.29	1.26	17.50
-5	5.51	2.86			2.95	1.62	14.76
-10					*5.07	4.66	7.59

1. The weight of bucket is 142kg  
2. Load point is the hook on the back of the bucket

3. \*Rated loads are based on hydraulic capacity  
4. Rated loads do not exceed 87% of HYD. Capacity or 75% of tipping capacity.



# DX55W

## Lifting Capacity

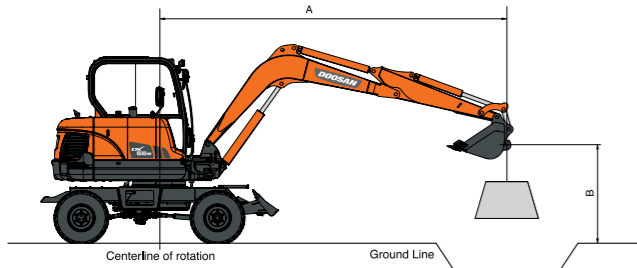

- A** : Load radius from centerline of rotation
- B** : Load point height
- : Rated lift capacity-over side (Free on Wheel/Dozer Up)
- : Rated lift capacity-over front (Free on Wheel/Dozer Up)

### Dozer up, Rear with 1,900mm(6'3") Arm

Metric Unit : 1,000kg

B(m)	2		3		4		5		Max. Reach		A(m)
5									*0.79	*0.79	4.10
4									*0.75	*0.72	4.89
3					*0.98	*0.98	0.79	0.68	0.70	0.61	5.35
2	*2.92	2.87	*1.63	1.49	1.10	0.95	0.77	0.67	0.65	0.56	5.55
1	*1.46	*1.46	1.63	1.39	1.05	0.91	0.75	0.64	0.63	0.54	5.55
O (Ground)	*1.99	*1.99	1.58	1.34	1.02	0.88	0.73	0.63	0.67	0.57	5.33
-1	*2.97	2.57	1.56	1.32	1.01	0.86			0.76	0.65	4.87
-2	3.14	2.61	1.58	1.34	1.02	0.88			1.00	0.86	4.05
-3	*2.97	2.70							*2.24	1.92	2.45

Feet Unit : 1,000lb

B(ft)	10		15		Max. Reach		A(ft)
15					*1.68	*1.68	14.74
10					1.56	1.35	17.49
5	3.61	3.09	2.03	1.76	1.40	1.20	18.30
O (Ground)	3.39	2.88	1.85	1.58	1.47	1.26	17.50
-5	3.37	2.86			1.89	1.62	14.76
-10					*5.07	4.66	7.59

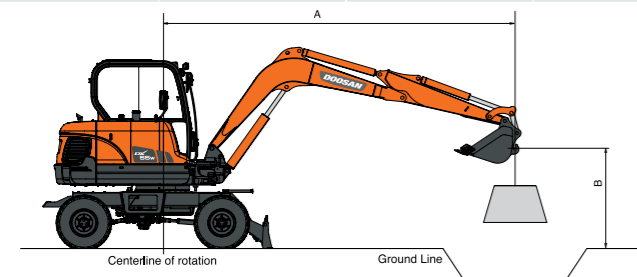

- A** : Load radius from centerline of rotation
- B** : Load point height
- : Rated lift capacity-over side (Free on Wheel/Dozer Up)
- : Rated lift capacity-over front (Free on Wheel/Dozer Up)

### Dozer down, Rear with 1,900mm(6'3") Arm

Metric Unit : 1,000kg

B(m)	2		3		4		5		Max. Reach		A(m)
5									*0.79	*0.79	4.10
4									*0.75	*0.75	4.89
3					*0.98	*0.98	*1.04	0.88	*0.76	*0.76	5.35
2	*2.92	*2.92	*1.63	*1.63	*1.30	1.22	*1.17	0.86	*0.80	0.72	5.55
1	*1.46	*1.46	*2.41	1.83	*1.65	1.17	*1.34	0.83	*0.90	0.71	5.55
O (Ground)	*1.99	*1.99	*2.86	1.77	*1.91	1.14	*1.47	0.82	*1.07	0.74	5.33
-1	*2.97	*2.97	*2.95	1.75	*2.00	1.13			*1.43	0.85	4.87
-2	*4.43	3.64	*2.69	1.77	*1.78	1.14			*1.74	1.12	4.05
-3	*2.92	*2.92							*2.24	*2.24	2.45

Feet Unit : 1,000lb

B(ft)	10		15		Max. Reach		A(ft)
15					*1.68	*1.68	14.74
10					*1.66	*1.66	17.49
5	*4.38	4.03	*2.22	*2.22	*1.86	1.56	18.30
O (Ground)	*6.16	3.80	*3.58	2.06	*2.37	1.64	17.50
-5	*6.19	3.78			*3.57	2.10	14.76
-10					*5.07	*5.07	7.59

1. The weight of bucket is 142kg  
 2. Load point is the hook on the back of the bucket  
 3. \*Rated loads are based on hydraulic capacity  
 4. Rated loads do not exceed 87% of HYD. Capacity or 75% of tipping capacity.

# DX55W

## Standard & Optional equipment

### STANDARD EQUIPMENT

#### Hydraulic system

- Arm flow regeneration
- Boom holding valves
- Spare ports(valve)

#### Cabin & Interior

- Rubber cab mount
- Air conditioner
- Adjustable suspension seat with head rest and adjustable arm rest
- Pull-up type front window and removable lower front window
- Room light
- Intermittent windshield wiper
- Storage box
- AM/FM radio and cassette player
- Remote radio ON/OFF switch
- 12V spare powers socket
- Serial communication port for laptop PC interface
- Joystick lever with 3 switches
- Aircon filter
- Glass antenna
- Room mirror

#### Safety

- Large handrails
- Seat belt
- Hydraulic safety lock lever
- Safety glass
- Hammer for emergency escape
- Right view mirror
- Left review mirror
- Emergency engine stop
- Accumulator
- Boom hose rupture protection valve

#### Undercarriage

- 12-16.5-12PR single tire
- Heavy duty axle
- Auto ram lock system
- 1,920mm dozer blade

#### Others

- Double element air cleaner
- Fuel pre-filter
- Aluminium radiator
- Engine overheat prevention system
- Engine restart prevention system
- Self-diagnostic system
- Alternator(12V, 60 amps)
- Electric horn
- Halogen working lights(frame mounted 2, boom mounted 2)
- Auto idle
- Fuel filler pump
- 2-way valve

### OPTIONAL EQUIPMENT

Some of these optional equipment may be standard in some markets. Some of these optional equipment cannot be available on some markets. You must check with the local DOOSAN dealer to know about the availability or to release the adaptation following the needs of the applications.

#### Safety

- Overload warning device
- Rotation beacon

#### Cabin & Interior

- Seat Heater
- MP3/CD player/Radio
- Additional working lamp
- Sunvisor

#### Others

- Piping for crusher
- Piping for tilting
- Piping for rotating
- 8.25 X 15 X 14PR double tire
- 2,290mm dozer blade