

* | 19,5 kW / 26,1 Hp at 2.200 rpm

▲ | 3.660 kg

📏 | 3.025 - 3.155 mm



DX35z | Compact Equipment



DOOSAN DX35z hydraulic excavator: a new model with novel features



The new DX35z (zero tail swing) hydraulic excavator offers additional value to the operator.

The new DX35z was developed with the concept of “providing optimum value to the end user”.

In concrete terms, this translates into :

- **Increased production** and **improved fuel economy** achieved with the electronic optimization of the hydraulic system and the new generation engine.
- **Improved ergonomics**, increased comfort and excellent all round visibility ensuring a safe and pleasant working environment.
- **Improved reliability**, using high performance materials combined with new methods of structural stress analysis, have lead to increased component life expectancy, thus reducing running costs.
- **Reduced maintenance** increases the availability and lowers the operating costs of the excavator.



Technical specifications



* Engine

• Model	YANMAR, 3TNV88
• Number of cylinders / Piston displacement	3 / 1.642 cc
• Nominal flywheel power	19,5 kW (26,1 Hp) at 2.200 rpm (SAE J1349) 19,5 kW (26,5 Ps) at 2.200 rpm (DIN 6271)
• Max torque	11,2 kgf.m (110 Nm) at 1.200 rpm
• Bore & stroke	88 mm x 90 mm
• Alternator	12 V / 40 Ah

* Operator's cab

• Noise Levels (dynamic value)	
• LwA External noise	
Guaranteed Sound Power Level (2000/14/EC)	94 dB (A)
• LpA Operator noise	81 dB (A) (ISO 6396)

* Hydraulic system

This original design enables both independent and combined operations of all functions, joystick control type operations.

• Main pumps	2 variable displacement axial piston pumps Max flow: 2 x 38,5 l/min + 1 fixed displacement gear pump 25,3 l/min (swing, boom swing & dozer)
• Pilot pump	Gear pump - max flow: 11,2 l/min
• Maximum system pressure	Boom/Arm/Bucket: 230 kgf/cm ² (225 bar) Travel: 230 kgf/cm ² (225 bar) Swing: 200 kgf/cm ² (196 bar)

* Swing mechanism

High-torque, axial piston motor with planetary reduction gear bathed in oil. Swing circle is single-row, shear type ball bearing with induction-hardened internal gear. Internal gear and pinion gear immersed in lubricant. A two position swing lock secures the upper structure for transportation.

• Swing speed	9,5 rpm
• Rear swing radius	850 mm

* Drive

Each track is driven by an independent, high-torque, axial piston motor through planetary reduction gears. Two levers control provide smooth travel or counter-rotation upon demand.

• Travel speed (high/low)	4,6/2,4 km/hr
• Maximum traction force	4.500/2.400 kgf
• Maximum grade	30° / 58 %

* Weight

Boom 2.405 mm • Arm 1.200 mm • Bucket SAE 0,11 m³ • Shoe 300 mm

• Operating weight	3.660 kg
• Ground pressure	0,33 kgf/cm ²

* Undercarriage

Tractor type undercarriage. Heavy-duty track frame, all welded stressrelieved structure. Top grade materials are used for toughness. Side frames are welded, securely and rigidly, to the track frame. Lifetimelubricated track rollers, idlers with floating seals. Hydraulic track adjusters with shock-absorbing recoil springs.

Lower rollers (per side)	4
Track shoes	Rubber
Shoe width	300 mm
Overall track length	2.123 mm

* Refill capacities

Fuel tank	42 l
Cooling system (radiator capacity)	5 l
Engine oil	6,3 l
Final drive (each)	0,5 l
Hydraulic tank	40 l

Performance

The highest performance is guaranteed in any working condition.

The advanced hydraulic system combined with a powerful engine provides the biggest break out and tractive forces for efficient operation.

As a result the DX35z provides outstanding performance, work efficiency and the ability to adapt to any work environment.

E/G Control Lever

The engine speed lever convenient location allows easy engine control.

3TNV88 Engine

The DX35z has a powerful and eco-friendly heart, that always provides high operating efficiency and pleasant working conditions.

Powerful Digging Force (Bucket)

Powerful, efficient, and with increased digging force.
Bucket Digging force : 3.000 kgf

Dozer Blade

Welded, unitized blade provides durability even under harsh working conditions.

Boom swing

The boom swing function permits to work in very narrow areas. The newly designed swing bracket and the increased boom cylinder size ensures powerful and stable swing performance.

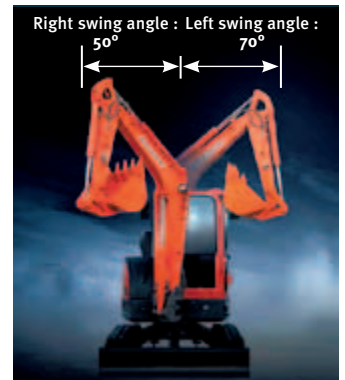
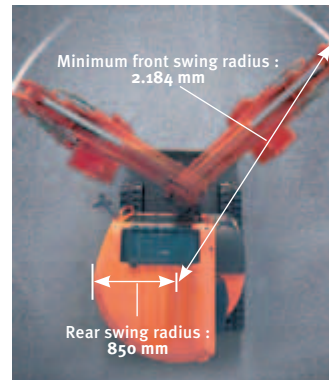

Comfort

The cabin has been ergonomically designed with comfort in mind.

Starting a fresh, the newly designed DX35z provides the operator with maximum comfort and various convenient features. The DX35z is the result of an innovative technical design!

The cabin space is more comfortable than any other excavator in its class.

Comfortable Operating Cabin

A ROPS-TOPS roomy, independant minimal shock and low noise operator's cab with safety glass provides all-round visibility. The right side window opens for ventilation and the front window slides up.

Monitor

The centralized display panel provides comprehensive information about the machine in an easy to read format. The high quality display panel is waterproof and all information can be seen at a glance. The ergonomically placed switches maximize convenience for the operator.

Control Stand

The left and right control stands are ergonomically placed for convenient operation. The control stand surfaces have ample room to install several option switches. The uni-body plastic design provides the operator with a spacious and comfortable cabin environment.

Joystick

The hydraulic joystick levers have very comfortable grips that allow the operator to perform precise operations very easily.

Arm Rest

A fully adjustable suspension seat provides operator comfort during long working days.

Cup Holder

The conveniently located cup holders add to the operator's comfort.

Defroster

The high capacity defroster, installed on the right, eliminating both frost and moisture very efficiently, provides a safer working condition for the operator. (Cabin Type Only)

Floor Plate (Rubber mat)

The breaker pedal (left) and boom swing pedal (right) are installed in a very spacious and convenient location. In addition, the rubber floor mats contribute to a very comfortable environment. The door opening has been increased by removing the lower lip which provides easy cleaning of the interior.



Comfortable sliding seat



Control stand Tilting Function

Maintenance

The status and condition of all components can be seen at a glance.
The convenient and easy serviceability is really distinguished.

The most advanced technology developed by Doosan Infracore Co., Ltd. was integrated into the DX35Z excavator for powerful performance and simple, easy maintenance. This provides the operator with convenient maintenance check points and maximizes the work efficiency of the DX35Z.

Easy maintenance

Access to the various coolers is very easy, making cleaning more convenient. The washer fluid level can be checked easily.

Air cleaner

The large capacity forced air cleaner removes over 99% of airborne particles, reducing the risk of engine contamination, increasing the cleaning and cartridge change intervals.

Air Breather

The hydraulic system was designed to prevent the pump from cavitating.

Strengthened Boom

The shape of the boom has been optimally designed using finite elements and 3-dimensional computer simulation, allowing the loads to be better distributed throughout the structure. This combined with increased material thickness means improved durability and reliability by limiting element fatigue.

Arm Assembly

In the arm assembly greater strength is gained by using cast elements and reinforcement around the bosses to increase the life of the component.

X-chassis

The X-chassis frame section has been designed using finite element and 3-dimensional computer simulation, to ensure greater durability and optimum structural integrity. The swing gear is solid and stable.

D-type Frame

The D-type frame and chassis frame add strength and minimize distortion due to shocks.

Engine Room

The engine compartment is designed for easier service and the sturdy sound proofing inside the engine cover reduces the noise to provide a more comfortable environment for the operator and those around it.

Bucket

Hardened bucket teeth provide durability and can be easily unbolted for removal, straightening or replacing.

Oil Gauge

Hydraulic oil level can be easily checked through the gauge on the side of the hydraulic tank.

Grease Piping

Integrated grease piping is designed for easy maintenance of the swing bearing and boom swing cylinder.

Rubber tracks

The rubber tracks offer greater non-slip and grip capabilities, are less harmful to sidewalks and road surfaces in urban environments. These rubber shoes can be easily installed or removed with the idler, sprocket and other main parts.

Standard and optional equipment

* Standard equipment

• Cabin & Interior

- All weather sound suppressed type cab
- Adjustable suspension seat
- Pull-up type front window and removable lower front window
- Room light
- Cigarette lighter
- Cup holder
- Heater and defroster
- Fresh air filter
- Storage box

• Safety

- ROPS & TOPS Cabin
- Hydraulic safety lock lever
- Side mirror
- Safety glass
- Hammer for emergency escape

• Others

- Double element air cleaner
- Water separator
- Alternator (12 V, 40 Ah)
- Electric horn
- Working lights
 - Boom mounted 1
 - Cabin mounted 2
- Piping for hammer (One way) & for rotation (Two way)
- Rubber shoe
- Maintenance free battery

* Optional equipment

• Safety

- ROPS & TOPS Canopy (4-Pillar)
- Rotating beacon
- Accumulator
- Travel alarm

• Others

- Track guards (front)
- Piping for quick clamp
- Lever pattern changing valve
- Air-conditioner

Dimensions and working ranges

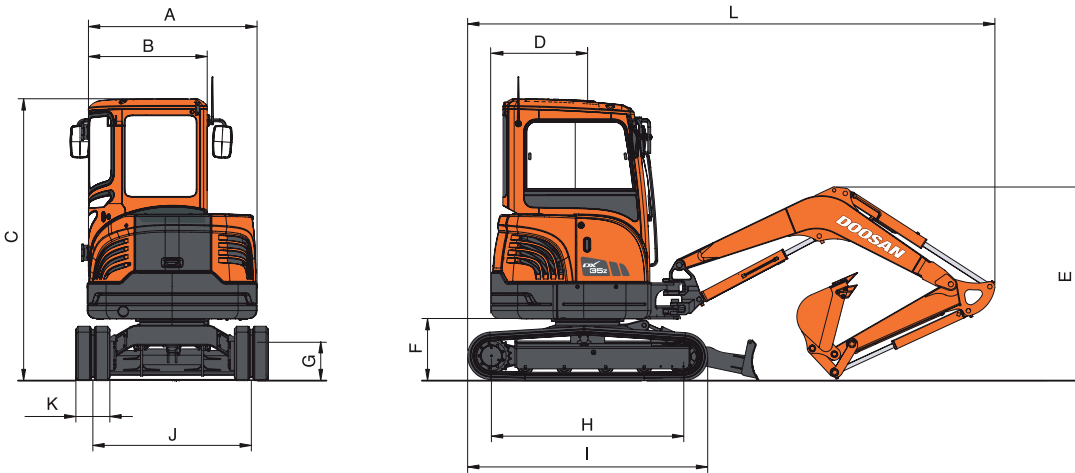

* Dimensions

Boom	2.405 mm
Arm	1.200 mm
A Overall width of upper structure	1.500 mm
B Overall width of cabin	1.030 mm
C Overall height of cabin	2.515 mm
D Tail swing radius	850 mm
E Boom transport height	1.720 mm
F Clearance under counterweight	575 mm
G Ground clearance	310 mm
H Tumbler distance	1.700 mm
I Track length	2.123 mm
J Track gauge	1.400 mm
K Track shoe width	300 mm
L Overall length	4.645 mm

* Digging force (ISO)

Bucket (PCSA)	0,11 m³	
Digging force	3.000 kgf	

Arm	1.200 mm	1.330 mm
Digging force	2.100 kgf	1.900 kgf

At power boost (ISO)

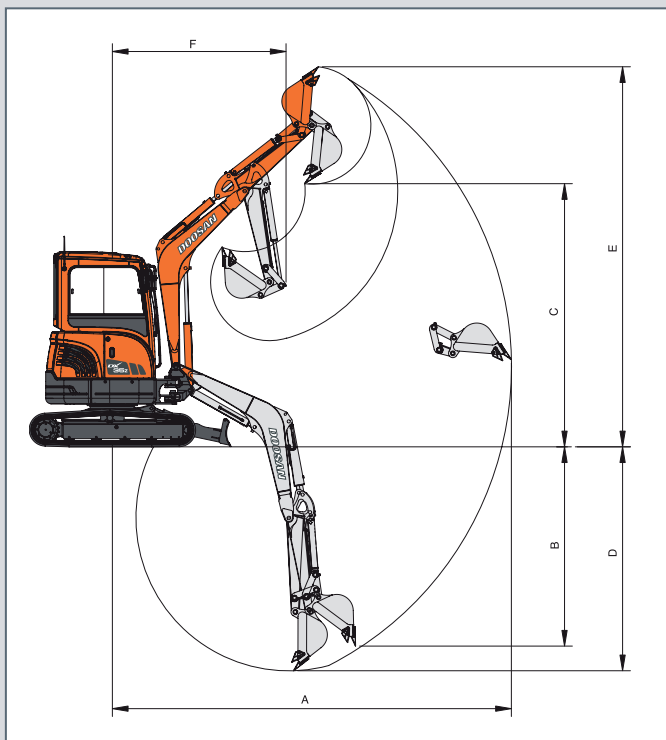

* Working range

Boom	2.405 mm	
Arm	1.200 mm	1.330 mm
Bucket type (SAE)	0,11 m³	
A Max. digging reach	5.090 mm	5.200 mm
B Max. vertical wall depth	2.560 mm	2.630 mm
C Max. loading height	3.350 mm	3.410 mm
D Max. digging depth	3.025 mm	3.155 mm
E Max. digging height	4.840 mm	4.880 mm
F Min. swing radius	2.210 mm	2.060 mm

Lifting capacity

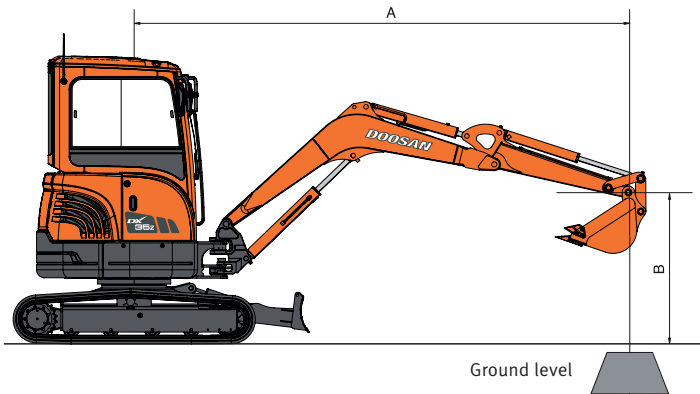

DOZER UP — Boom: 2.405 mm - Arm: 1.200 mm - Bucket: SAE 0,11 m³ (CECE 0,094 m³) - Shoe: 300 mm

Units: 1.000 kg

A (m) \ B (m)	2		3		4		Max. reach		A(m)
4							*0.77	*0.77	2.76
3			*0.67	*0.67			0.48	0.47	3.76
2			0.70	0.69	0.43	0.42	0.39	0.38	4.21
1			0.67	0.65	0.42	0.41	0.36	0.36	4.34
o (ground)	1.23	1.18	0.64	0.63	0.41	0.40	0.38	0.38	4.18
-1	1.25	1.20	0.64	0.63			0.47	0.46	3.68
-2	1.30	1.25					*0.84	0.83	2.59

DOZER UP — Boom: 2.405 mm - Arm: 1.330 mm - Bucket: SAE 0,11 m³ (CECE 0,094 m³) - Shoe: 300 mm

Units: 1.000 kg

A (m) \ B (m)	2		3		4		Max. reach		A(m)
4							*0.71	*0.71	2.95
3							0.46	0.45	3.89
2			0.71	0.69	0.43	0.42	0.37	0.36	4.33
1			0.67	0.65	0.42	0.40	0.35	0.34	4.45
o (ground)	1.22	1.18	0.64	0.62	0.41	0.40	0.36	0.36	4.30
-1	1.24	1.19	0.64	0.62			0.44	0.43	3.82
-2	1.28	1.24					0.74	0.73	2.80

DOZER DOWN — Boom: 2.405 mm - Arm: 1.200 mm - Bucket: SAE 0,11 m³ (CECE 0,094 m³) - Shoe: 300 mm

Units: 1.000 kg

A (m) \ B (m)	2		3		4		Max. reach		A(m)
4							*0.77	*0.77	2.76
3			*0.67	*0.67			*0.73	0.47	3.76
2			*0.88	0.69	*0.75	0.41	*0.74	0.38	4.21
1			*1.18	0.65	*0.84	0.40	*0.78	0.36	4.34
o (ground)	*1.29	1.18	*1.34	0.63	*0.89	0.39	*0.82	0.38	4.18
-1	*2.17	1.20	*1.26	0.63			*0.87	0.46	3.68
-2	*1.31	1.25					*0.84	0.83	2.59

DOZER DOWN — Boom: 2.405 mm - Arm: 1.330 mm - Bucket: SAE 0,11 m³ (CECE 0,094 m³) - Shoe: 300 mm

Units: 1.000 kg

A (m) \ B (m)	2		3		4		Max. reach		A(m)
4							*0.71	*0.71	2.95
3							*0.69	0.45	3.89
2			*0.82	0.69	*0.71	0.42	*0.71	0.36	4.33
1			*1.14	0.65	*0.81	0.40	*0.74	0.34	4.45
o (ground)	*1.46	1.18	*1.33	0.62	*0.88	0.40	*0.79	0.36	4.30
-1	*2.26	1.19	*1.28	0.62			*0.85	0.43	3.82
-2	*1.49	1.24					*0.86	0.73	2.80

1. The nominal forces are based on the SAE J1097 standard.

2. The load point is the hook at the rear of the bucket.

3. * = The nominal loads are based on hydraulic capacity.

4. The nominal loads do not exceed 87% of the hydraulic capacity or 75% of the capacity of the swing.

: Over front
 : Over side or 360°



Doosan Infracore
Construction Equipment



FSC
Mixed Sources
www.fsc.org/coc
©2010 FSC